

Reglus Electrode Holder

for EDM die-sinking systems, suitable for copper tube electrodes between dia. 0.3 to 5.0 mm

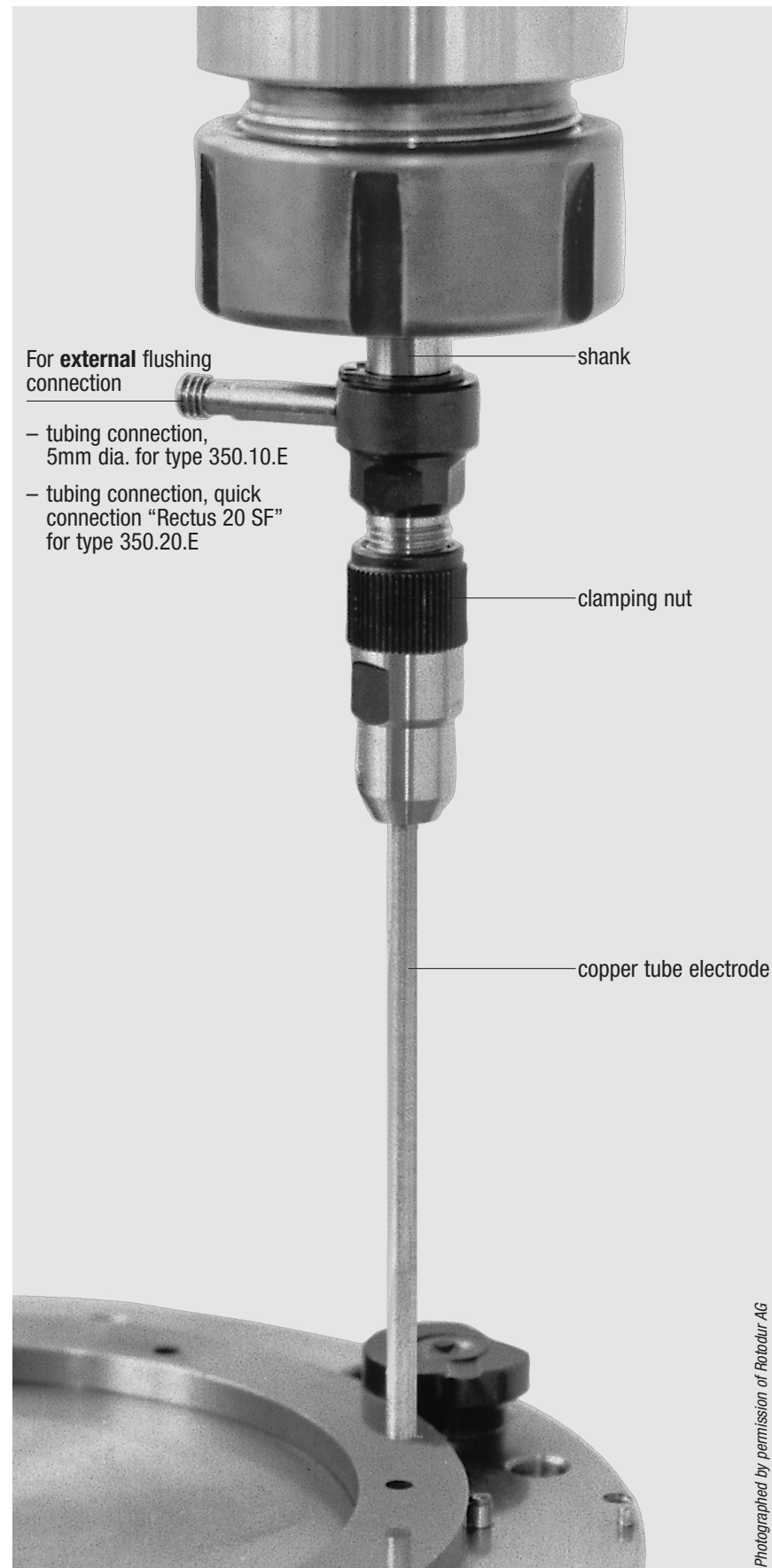

The Reglus Electrode Holder gives 5-fold economy

1. Reduces cleaning work and costly spindle overhauling and thus less idle time of the machine thanks to the external flushing connection*
2. Increases the machining capacity thanks to the rotating electrode with flushing
3. The symmetrical double cone collets allow an even but strong clamping of the usually thin-walled copper electrode tube (clamping range is dia. 0.3 to 5.0 mm with 11 collets).
4. Also suited for finishing cuts thanks to good roundness accuracy (+/- 0.015 mm typical)
5. Suitable in narrow places thanks to its small diameter (dia. of the front part of the clamping nut is only 11.5 mm)

*Reglus also offers an electrode holder with internal flushing facility (type 350.20.I).

Photographed by permission of Robdur AG

Reglus Electrode Holder with external rotatable flushing connection in action on an Agietron Compact machine

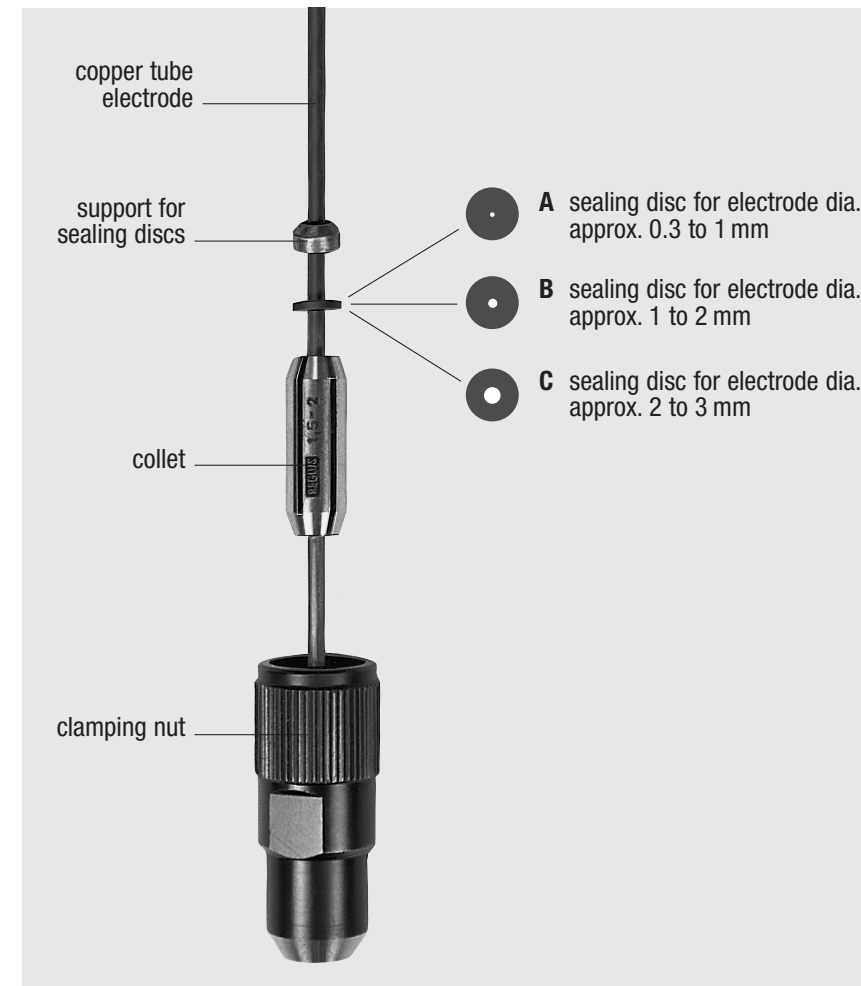

Easy to install

1. Select suitable sealing disc (dependent on electrode dia.)
2. Slide sealing disc on electrode
3. Slide support for sealing disc (plain side towards disc) on the electrode close to the sealing disc
4. Slide collet on the electrode (towards the sealing disc)
5. Slide the clamping nut over the electrode and the collet
6. Put the electrode about 30 mm inside the body
7. Tighten the clamping nut according to the requirement either by hand or with the included single ended spanner

The assembling of an electrode can be done either on the machine or on a presetting tool.

For copper tube electrodes above an outside dia. of approx. 3 mm neither sealing discs nor sealing disc supports are required.

The exchange of an electrode is done in the reverse order.

Types

- 350.10.E** Reglus electrode holder with dia. 10 mm shaft and rotatable **external** connection for the flushing liquid
- 350.20.E** Reglus electrode holder with dia. 20 mm shaft and rotatable **external** connection for the flushing liquid
- 350.20.I** Reglus electrode holder with dia. 20 mm shaft and an **internal** connection (through the machine spindle) of the flushing liquid

Packing list

- A set (in a wooden box) comprises the following parts:
- 1 electrode holder
 - 1 set of collets (11 sizes) covering a total span of dia. 0.3 to 5.0 mm
 - 10 each sealing discs size A, B and C
 - 1 sealing disc support
 - 2 single ended spanners of 12 mm A/F

Technical Assistance, Sales and Service:

Manufacturer:

Reglus AG
 Fine Mechanics and Electronics
 CH-8134 Adliswil, Soodstrasse 59
 Switzerland
 Telephone +41-1-710 50 11
 Telefax +41-1-710 14 80

Agencies in more than 30 countries